



# PETERSON

Vehicle Lighting & Harness Systems

# LED Cove Lights

## Tired of stumbling around dark trailers? Peterson has the solution for you!



This image shows how the traditional arrangement of recessed ceiling dome lights in a 53' trailer cause many dark areas from cargo shadows.



**PATENTED**

This image shows a 53' trailer with our 359 lights installed. You can see the shadows are greatly reduced. As a bonus, the upfront costs and TCO are lower too.

## 359 LED Cove Lights

Now available in kits for 53', 48', 33' and 28' trailers

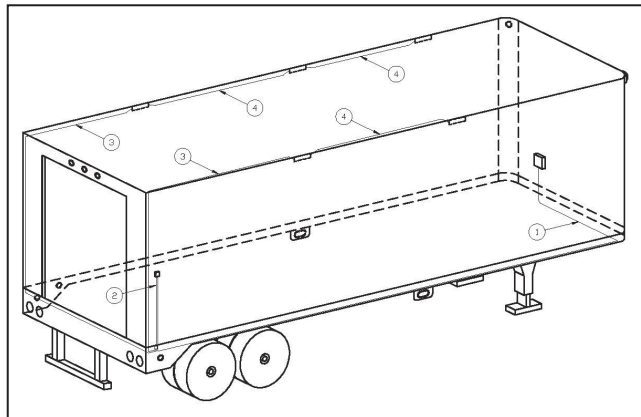

**Call or E-mail for more details**

For illustration purposes: 53' trailer kit with rear-mounted timer switch. Includes 5 lights, 8 harnesses and 1 timer switch.



# PETERSON

Vehicle Lighting & Harness Systems

## 359 LED Cove Lights

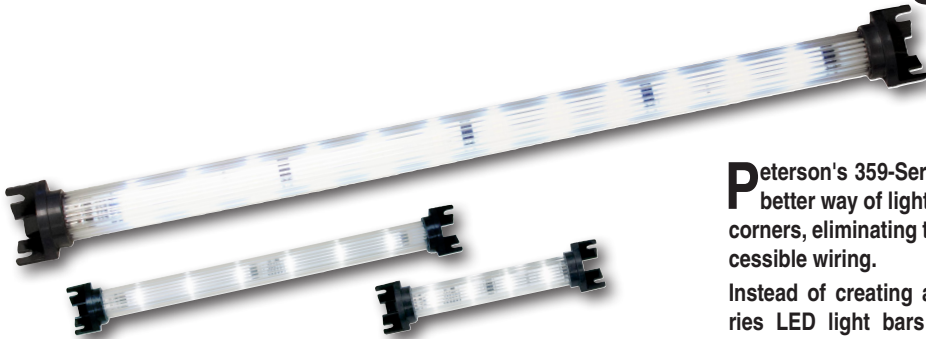

359 Series lights are available in 6", 12" and 18" lengths.

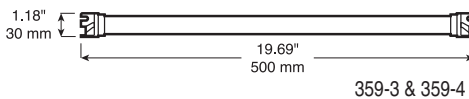
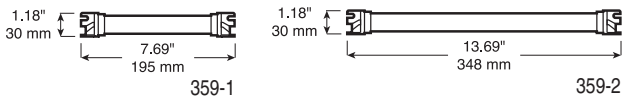

### 5600 Timer Box Switch

The 5600 timer switch is designed to integrate with Peterson's innovative 359 series cove lights to create the most advanced, efficient cargo illumination system on the market.



- 10 amp maximum load.
- Pre-programmed for 30 minutes of ON time per button push.
- Additional time can be added at any time.
- Lights flash per button push to indicate that command is received.
- Pushing and holding button turns off lights at any time.
- "2 minute warning" slowly dims and raises light level prior to shut-off.
- 9–32 volt operating range.

Order No.	Description	Leads	Intervals	Max Time	Pack	Std Carton
P5600	surface mount	8"	30 min	120 min	poly pack	12
P5600-1	surface mount	8"	30 min	120 min	poly pack	12
5600	surface mount	8"	30 min	120 min	mfg. pack	50
5600-1	recessed mount	8"	30 min	120 min	mfg. pack	50
5601	recessed mount, orange	8"	60 min	60 min	mfg. pack	50
5602	surface mount	8"	90 min	90 min	mfg. pack	50
5603	surface mount, 2 plugs	90"	30 min	120 min	mfg. pack	2

Peterson's 359-Series LED cove mounted light bars are an innovative, better way of lighting interior cargo spaces. These lights mount in the corners, eliminating the need for a mounting pan, in-wall conduit, or inaccessible wiring.

Instead of creating a hot-spot directly under a recessed light, 359-Series LED light bars are strategically located in the corners to light the trailer around the cargo with a flood of evenly distributed light. These lights also cost less to purchase and install compared to old, recessed ceiling lights—even when equipped with the recommended higher number of lights. Another benefit is lower energy consumption thanks to a reduced amp draw.



Mounts easily to horizontal and/or vertical surfaces



Scan with smartphone to learn more!

### 359 LED Cove Light



- More effective light distribution than recessed dome lights.
- No mounting pan needed, so the R-value of insulated cargo areas is not reduced.
- Easy and versatile surface screw mounting on any vertical or horizontal surface.
- Multi-volt design is compatible with both 12V and 24V systems.
- 3.5" long stripped lead wires standard. 18" version also available with .180 bullets.
- 359-4 & 359-4-BT2 have wires on both ends so that they can be wired in series.
- IP67 rated — Integral molded seal resists dust, moisture and vapors.
- Accessory cove molding facilitates easy wiring for retrofits.

Order No.	Description	Lumens	Pack	Std Carton
359-1	6" long, stripped leads	300	poly pack	12
359-2	12" long, stripped leads	500	poly pack	12
359-3	18" long, stripped leads	1000	poly pack	12
M359-1	6" long, stripped leads	300	mfg. pack	50
M359-2	12" long, stripped leads	500	mfg. pack	50
M359-2-BT2	12" long, .180 bullets	500	mfg. pack	50
M359-3	18" long, stripped leads	1000	mfg. pack	50
M359-3-BT2	18" long, .180 bullets	1000	mfg. pack	50
M359-4	18" long, dual-end stripped leads	1000	mfg. pack	50
M359-4-BT2	18" long, dual-end .180 bullets	1000	mfg. pack	50

LED Cove Lights 359-0921-B